

PISTON FILLERS/DEPOSITORS

SP-64 Single Piston Model

The Hinds-Bock standard single-piston filler/depositor is the classic workhorse of the food processing industry. Easy to clean and operate, versatile and gentle on all products, it provides immediate cost-saving results. Large port openings permit filling of chunky ingredients without crushing. USDA and AG Canada approved.

PARTIAL PRODUCT LIST

Jams and Jellies
Pie Fillings
Cake Batters
Flowable Doughs
Fruit Cake Batters
Mayonnaise
Salad Dressings
Mustard
Potato Salad
Macaroni Salad
Cole Slaw
Burrito Fillings
Meat Pie Fillings
Stews
Soups and Sauces
Quiche Filling
Crepes
Ice Cream and Pudding
Cottage Cheese
Creamed Spinach
Apple Butter
Creams and Lotions
HOT OR COLD PRODUCTS

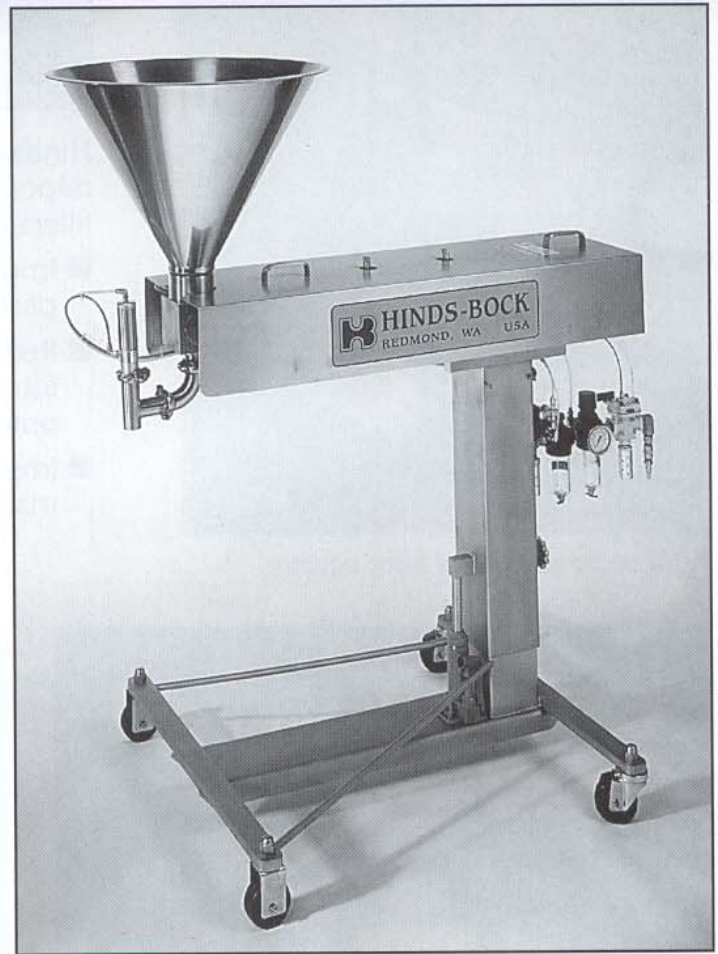

STANDARD FEATURES

- Air powered - consult factory for compressed air requirements
- 14 inches of height adjustment
- Locking swivel casters
- Stainless steel construction with all contact parts of food-approved materials
- Fills from fractions of an ounce to 64 ounces with change cylinders
- Pneumatic dump system with interlocked safety cover



HINDS-BOCK CORPORATION
14690 NE 95th St., Redmond, WA 98052

E-mail: info@hinds-bock.com
425-885-1183
Fax 425-885-1492

Options Available to Match Process Requirements

Options Include: Conical (10-20 gallon) hoppers, "U"-shaped agitated hoppers, change cylinders, a variety of spouting, automatic & semi-automatic controls, level probes, agitators . . . all matched to customers' applications.



"U"-hopper with helical blade agitator

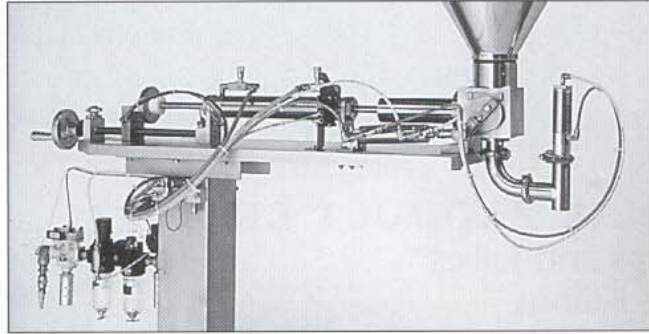

Hinds-Bock has specialized in the design of fillers/depositors since its beginnings. These labor-saving fillers/depositors all provide:

- Improved quality when depositing large, delicate particulates, damage free.
- Reduced costs with accurate filling/depositing into trays, bottles, cans, pouches, or targeted onto product as in tortillas pictured below.
- Improved payback with versatility, ease of maintenance and operation.

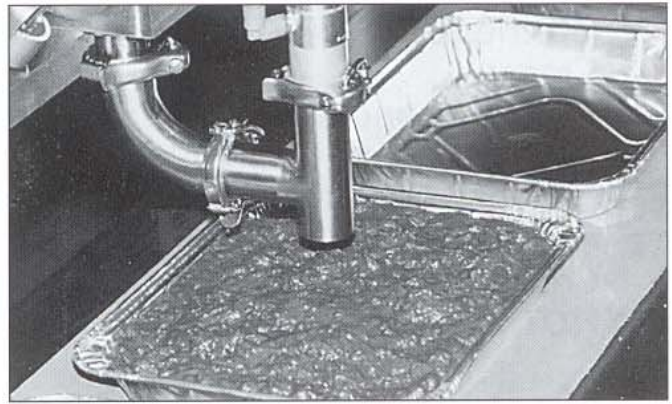
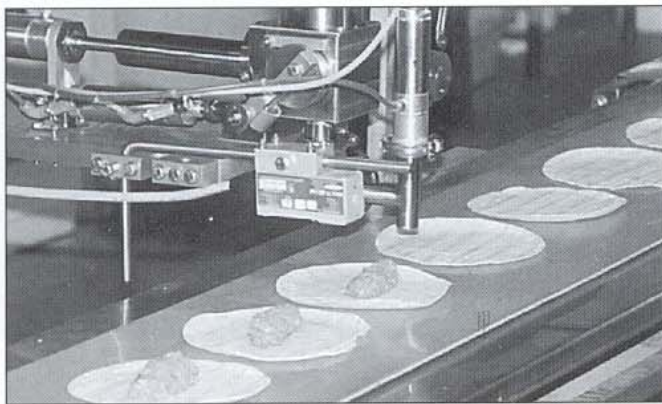

**ASK ABOUT CUP & TRAY DENESTERS AND LID APPLICATORS.
ASK ABOUT TRANSFER PUMPS TO FILL THE HOPPER.**

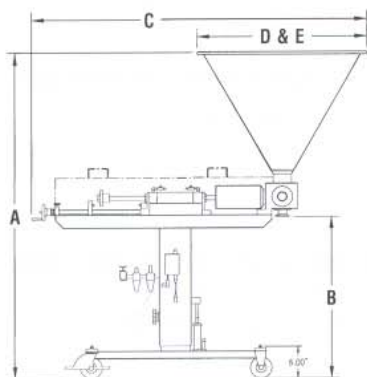

Standard Model Specifications

MODEL	A	B	C	HOPPER WIDTH		* REQ'D CFM
				D	E	
SP-64 SINGLE PISTON	59" - 74"	33.5" - 43"	53"	25.75"	N/A	4 - 6

*Approximate CFM. Consult factory for exact CFM requirements.